



274 Church Street
Onehunga

System Control Engineering NZ Ltd

THE GAS BIZZ BULLETIN

August 2010

"GASGUARD"

Gas Safety Protection System

Is designed as a **SAFE** and **RELIABLE** start up protection for any system.

Typical uses are:

- Kitchens
- Boiler rooms
- Fume cupboards
- School Laboratories & Home Economics Blocks

Available in pipe sizes from 15 mm to 150mm,
The system is inexpensive and simple to use.

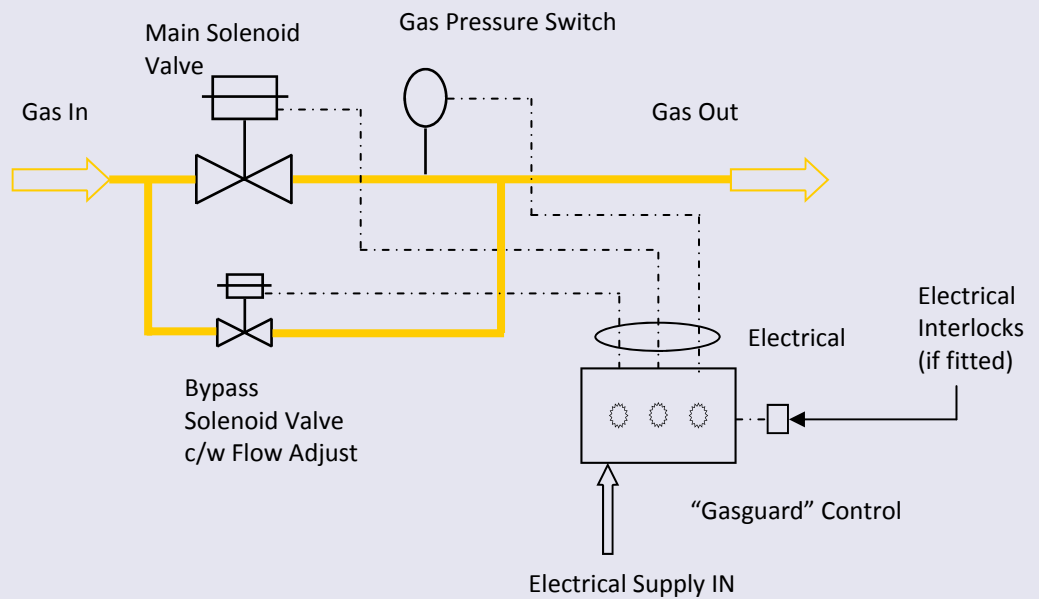

The above is a simple diagram of how the system is put together

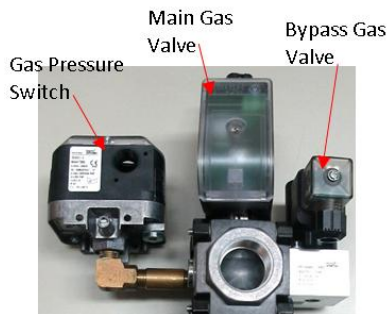

Phone: 09 636 1401 Fax: 09 636 1525
 Email: sales@systemcontrol.co.nz
www.systemcontrol.co.nz

EVERY APPLIANCE REQUIRES A REGULATOR

Continued on from the July 2010 Gas Bizzz...

LPG REGULATORS:

Can be classified as: First stage, Second stage and Two stage. Auto-changeover regulators are a combination of two first stage regulators and one second stage regulator.

First stage:

LPG regulators accept cylinder pressure on the inlet, typically 700 kPa, and reduce to levels of 20-200kpa (3 - 30psig) outlet pressure.

Second stage:

Most second stage LPG regulators accept inlet pressures of up to 70kPa maximum and reduce to levels of 1-35 kPa

Two stage:

Two stage regulators are a combination/assembly of a first stage regulator and a second stage regulator and are required as a minimum standard for commercial installations.

LPG BBQ regulators are an example of high pressure breakdown regulators because they have the ability to "lock-up" tight against the high inlet cylinder pressure on the inlet when shut-down. They deliver low pressure on the outlet, typically 2.75 kPa and they provide over-pressure protection to the low pressure burner equipment downstream.

POPULAR REGULATORS THAT ARE AVAILABLE AT SCE



Read our next month's Gas Bizzz for more information on Regulators...

Geca Carbon Monoxide Detector



Part Number:
GE.ID155

- 0-1000ppm co measuring range.
- +/- 1% scale resolution (+/- 1 digit).
- 9v DC battery.
- >200h battery life.
- Auto switch off after 10 minutes.
- > 60 seconds stabilising time.
- 80x187x32mm dimensions

geca

Place your order now!!!

Don't forget we sell Gas Leak Detector Spray



SMRVS100401

Now only \$8.00+GST+Freight

Quote of the Month

"Always forgive your enemies - Nothing annoys them so much".

BACHARACH
Leak Detectors
Flue Gas Analysers

BRAHMA
Pilot Burners
Burner Controls
Ignition Transformers
Gas Solenoid Valves

BROMIC
Appliance Regulators

CAMPINI
Thermostats

CATOBA
Pilots
Controls
Gas Valves

DIGITRON
Digital Manometers

DORMONT
Flexible S.S. Connectors
Quick Disconnect Couplings

DUNPHY
Gas, Oil & Dual Fuel Burners

ECOFLAM
Package Burners

GECA
CO Detectors
Gas Detectors

FLAMEFAST
Hot Metal & Heat
Treatment Equipment

ITAP
Gas Ball Valves

JEAVONS
OPSO Regulators
Appliance Regulators

KROMSCHRODER
Gas Filters
Gas Meters
Pilot Burners
Pressure Switches
Gas Solenoid Valves

MADAS
Gas Filters
Regulators

NAMCO
Combustion Equipment

OARA
LP Gas Regulators

PH PRODUCTS
Smoke Pallets

POLIDORO
Blade Burners
Atmospheric Burners

REGO
LP Gas Regulators

RIELLO
Package Burners

ROBERTSHAW
Pilot Burners
Thermocouples
Gas Control Valves

SATRONIC
Burner Controls

SCE
Test Points
Petes Plugs
Test Nipples
U-Tube Manometers

SEITRON
Gas Detectors

SHERWOOD
Auto Changeover Regulators

SIT
FFD's,
Flame Rods
Gas Controls
Ignition Electrodes

WHITE-RODGERS
Gas Control Valves