

274 Church Street
Onehunga
Auckland

System Control Engineering NZ Ltd
For Gas, Combustion & Control Equipment

THE GAS BIZZ BULLETIN

May 2009



“Gasguard” Gas Safety Protection System

**is designed as a SAFE and RELIABLE
start up protection for any system.**

Typical uses are:

- Kitchens
- Boiler rooms
- Fume cupboards
- School Laboratories & Home Economics Blocks

Available in pipe sizes from 15 mm to 150 mm,
the system is inexpensive and simple to use.

1. Main Gas Valve
2. Gas Pressure Switch
3. Bypass Valve
(Integral with Item.1)
4. Bypass Flow Limiting
Valve
(Integral with Item .3)
5. Gasguard Control
Panel
6. Optional System
Stop Interlocks

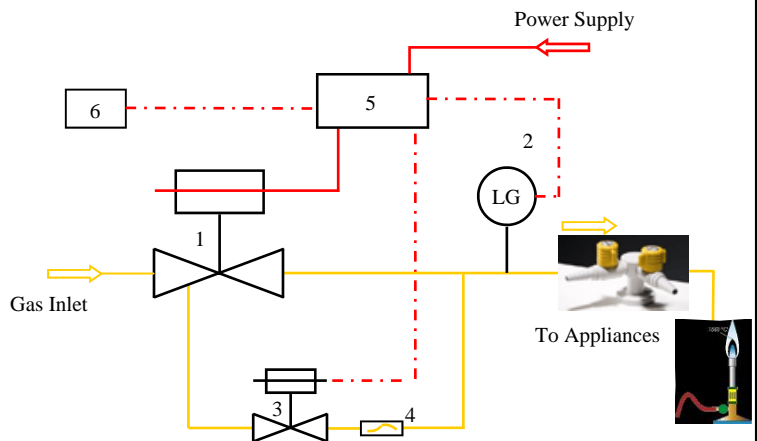

Control Panel (Item 5)



Gas valve c/w
Bypass
& Flow
Limiting Valve
(Items 1,3 & 4)



Gas
Pressure
Switch
(Item 2)



Phone: 09 636 1401 Fax: 09 636 1525
Email: sales@systemcontrol.co.nz
www.systemcontrol.co.nz



Dave's Technical Tip

REGULAR MAINTENANCE

REFER NZS 5261:2003 APP.J1/J2 – GAS APPLIANCE MAINTENANCE

Effect of Regular Maintenance:

- ENSURES CORRECT COMBUSTION**
- MAINTAINS EFFICIENCY**
- MEETS OWNER/OPERATOR LEGAL RESPONSIBILITY**

Maintenance should be undertaken at the very least, annually, to prepare the appliance for another twelve months operation.

It includes but is not limited to:

- Checking the burner appliance and flue for wear, corrosion, leakage and blockage.
- Checking and cleaning all room/ ventilation louvres, grilles, appliance air filters, air inspirators and air fan impellers.
Where air quality is poor, more frequent maintenance of these items is necessary.
- Burner operating pressure should be checked to the data plate figure.
- Gas rate and flue gas analysis/ Carbon Monoxide emissions.
- Replace thermocouples, spark and ionisation probes (they usually fail a week later).
- If you replace/adjust/maintain, any part of a gas appliance you will need to verify that the combustion is correct when you leave site and ideally provide a copy of the flue gas analysis.

RIELLO BURNERS

DON'T FORGET.....

We now have Riello Burners in stock



11kW to 2290kW Gas Burners

On/Off, Hi/Lo, Modulating

28kW to 1482kW Light Oil Burners



Gas Leak Detector Spray



Save the mess in your van.
Buy your leak detector in the can.

- Practical & economical
- Suitable for all gasses (flammable & non-flammable)
- Non Flammable
- Non toxic
- Complies with strict environmental standards

SMRVS100401



Quote of the Month

"Elephants are the only animals that can't jump"

BACHARACH
Leak Detectors
Flue Gas Analysers

BRAHMA
Pilot Burners
Burner Controls
Ignition Transformers
Gas Solenoid Valves

BROMIC
Appliance Regulators

CAMPINI
Thermostats

CATOBA
Pilots
Controls
Gas Valves

DIGITRON
Digital Manometers

DORMONT
Flexible S.S. Connectors
Quick Disconnect Couplings

DUNPHY
Gas, Oil & Dual Fuel Burners

ECOFLAM
Package Burners

GECA
Gas Detectors
CO Detectors

FLAMEFAST
Hot Metal & Heat
Treatment Equipment

ITAP
Gas Ball Valves

JEAVONS
OPSO Regulators
Appliance Regulators

KROMSCHRODER
Gas Filters
Gas Meters
Pilot Burners
Pressure Switches
Gas Solenoid Valves

NAMCO
Combustion Equipment

OARA
LP Gas Regulators

PH PRODUCTS
Smoke Pallets

POLIDORO
Blade Burners
Atmospheric Burners

REGO
LP Gas Regulators

RIELLO
Package Burners

ROBERTSHAW
Pilot Burners
Thermocouples
Gas Control Valves

SATRONIC
Burner Controls

SCE
Test Points
Petes Plugs
Test Nipples
U-Tube Manometers

SEITRON
Gas Detectors

SHERWOOD
Auto Changeover Regulators

SIT
FFD's,
Flame Rods
Gas Controls
Ignition Electrodes

WHITE-RODGERS
Gas Control Valves